

Original Instructions

Electric scooter

User Manual

Model S9 PLUS /S9 PLUS DUAL

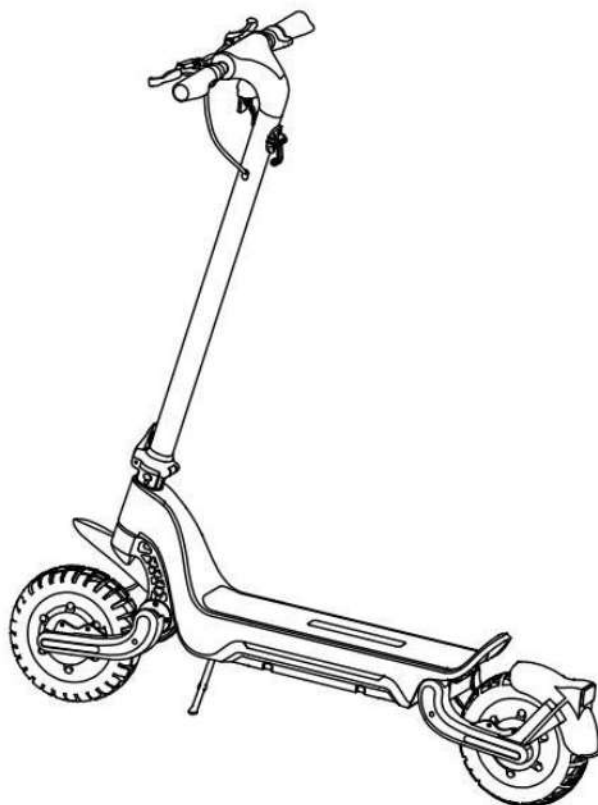

"IMPORTANT! Read carefully and keep it for future reference!"

Contents

1 Riding Safety -----	04
2 Packing List -----	06
3 Diagram -----	07
4 Assembling Your Electric Scooter -----	09
5 First Ride -----	10
6 Charging -----	12
7 Learning to Ride -----	13
8 Warnings -----	16
9 Maintenance -----	21
10 Parameters-----	23
11 Declaration of Conformity-----	24

Thanks for choosing the Electric scooter!

- Thanks for choosing our electric scooter, which is a fashion and leisure device. Our electric scooter is not intended for use by persons (including children) who are not good at physical, sensory, or mental capabilities, or lack experience and knowledge unless they have been given supervision or instruction by a person responsible for their safety.
- To bring a comfortable riding feeling, please make sure to read our instructions carefully before using.

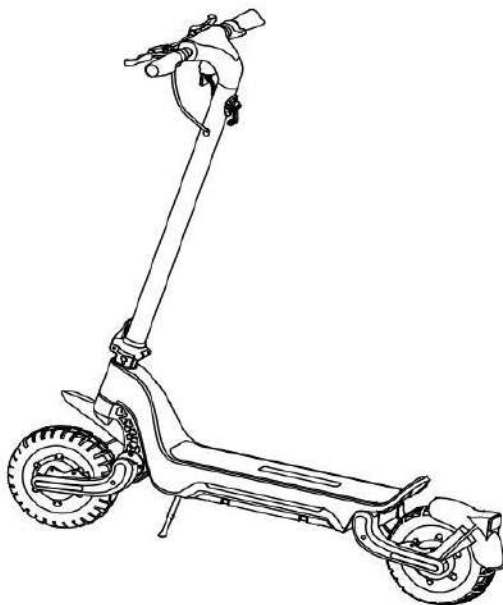

(for illustration only)

1 Riding Safety

- Don't use any accessories and any additional items which are not approved by the manufacturer.
- Don't slam the brake. Please use your right brake lever first. We adjust our left brake lever softly to avoid roll-over when slammed. Warning on the extension of braking distances during wet weather.
- Please ride on a flat, clean, dry level and if possible, a distance from other road users.
- Before riding our vehicle, please check that the steering system is correctly adjusted, that all connection elements (such as the folding system) are correctly tightened and not broken, and that the brakes and wheels are in good condition.
- Make sure that always wear shoes before riding.
- Please turn on the lights when riding at dark, and at a lower speed.
- "WARNING! As with any mechanical component, a vehicle is subject to high stresses and wear. The various materials and components may react differently to wear or fatigue. If the expected service life for a component has been exceeded, it may break suddenly, therefore risking causing injuries to the user. Cracks, scratches, and discoloration in the areas subject to high stresses indicate that the component has exceeded its service life and should be replaced."
- Traffic in the city has many obstacles to cross such as curbs or steps. It is recommended to avoid obstacle jumps. It is important to anticipate and adapt your trajectory and speed to those of a pedestrian before crossing these obstacles. It is also recommended to get out of the vehicle when these obstacles become dangerous due to their shape, height, or slippage.
- "WARNING! Keep plastic covering away from children to avoid suffocation.
- Please keep the printed instructions for further reference and read them carefully before use.
- The maximum pressure for inflatable tires is 250kPa/36PSI.
- Take the time to learn the basics of the practice to avoid any serious accident that can take place in the first months.
- Get closer to your seller so he can refer you to an appropriate training organization.

- Avoid high-traffic areas or overcrowded areas.
- In any case, anticipate your trajectory and your speed while respecting the code of the road, the code of the sidewalk, and the most vulnerable.
- Notify your presence when approaching a pedestrian or cyclist when you are not seen or heard.
- Cross the protected passages while walking.
- In all cases, take care of yourself and others.
- Do not divert the use of the vehicle.
- This vehicle is not intended for acrobatic use.
- Caution, the brake may become hot in use. Do not touch after use.
- Regularly check the tightening of the various bolted elements, in particular the wheel axles, the folding system, the steering system, and the brake shaft.
- Eliminate any sharp edges caused by use.
- Do not modify or transform the vehicle, including the steering tube and sleeve, stem, folding mechanism, and rear brake.
- The A-weighted emission sound pressure level at workstations is 55 dB (A).
- The vibration total value to the hand-arm system is $<2.5\text{m/s}^2$.
- The user should check the limits of use in accordance with the local regulations (e.g. use in pedestrian areas, on-road).
- Always engage the parking device when the vehicle is not in use.
- Warning: the self-tightening nuts as well as the other self-tightening fastenings may lose their efficiency and that they may need to be re-tightened.

2 Packing List

Assembled Electric Scooter

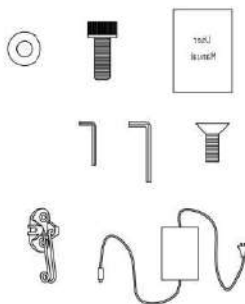
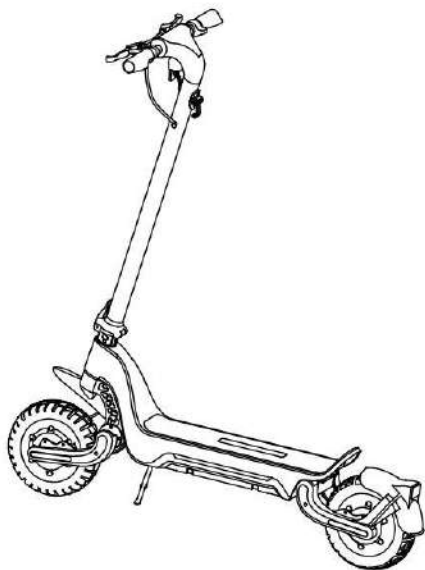

User Manual x1

tool kit x1

Headlamp gasket x1

Hook x1

Charger x1

When unpacking your Electric scooter. Please verify that the above items are included in the package. If you are missing any components. please contact your dealer/distributor or nearest service center. After verifying that all components are present and in good condition, you can assemble your new Electric scooter Please retain the box and packing materials in case you need to ship your Electric scooter in the future Remember to power off your Electric scooter and unplug the power

card before assembling mounting accessories, or cleaning the mainframe.

3 Diagram

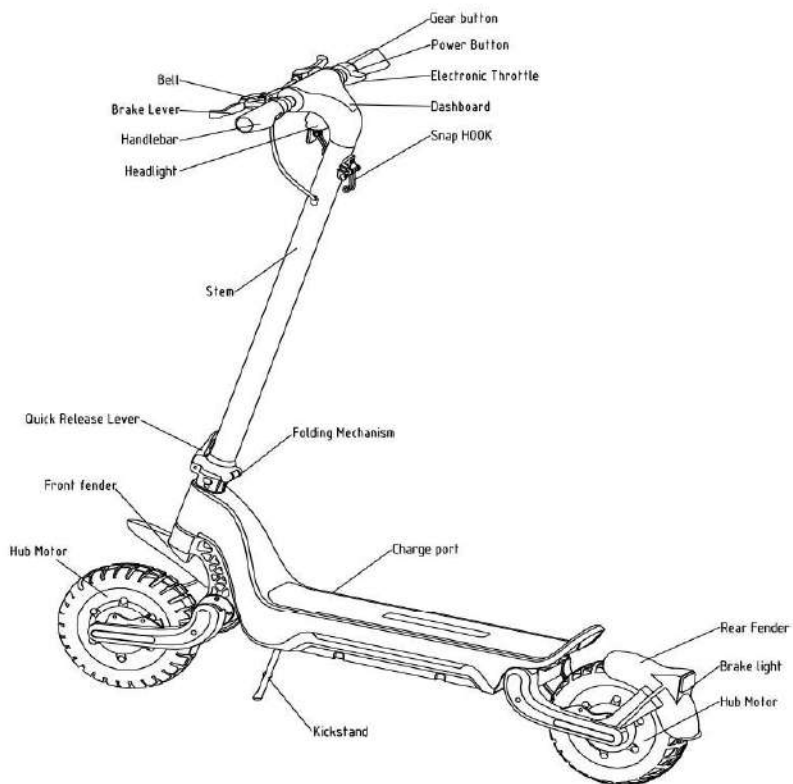

Dashboard&Power Button

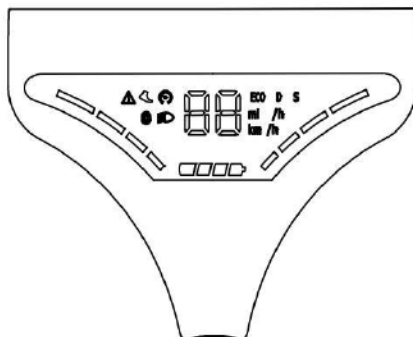

The layout of the display

The speedometer Displays the current speed of the Electric scooter, as well as displays error codes.

Modes:Four modes available

🚶 Pedestrian mode: Makes pushing the Electric scooter easier.

“ECO” for Energy saving mode(smooth acceleration suitable for beginners)

“D” for Standard mode

“S” for Sport mode(powerful.only recommended for skilled riders)

Bluetooth: The icon indicates that the Electric scooter has been successfully connected to the mobile device.

Error: The wrench icon indicates that the Electric scooter has detected an error.

Battery Level: The battery powers are indicated by 4 bars, The first bar is about 40% of the battery power, and the remaining 20% of the battery power is per bar.

Power button: press this button to turn on the electric scooter, press the gear button, click to turn on the light, and double-click to switch gears between modes. The power button for 3 seconds turns off the electric scooter when it is turned on.

4 Assembling Your Electric scooter

1 Unfold the handlebar stem and fasten



2 Firmly connect the wires inside it. Then unfold the kickstand to the handle and the stem. Slide the handle to support the Electric scooter. onto the stem. Be aware of the correct orientation.



3 Install seven screws (two on each side).

4 Verify that your Electric scooter can have headlight powered on and off.

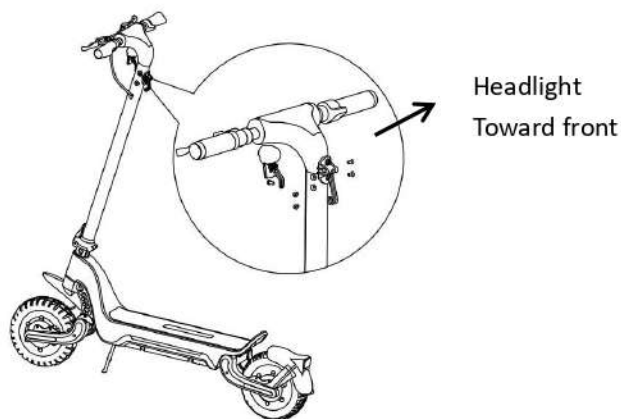

5 First Ride



扫描下方二维码MiniRobot App

Android



扫描下方二维码MiniRobot App

IOS

There are safety risks when learning to ride an Electric scooter. You must read the Riding Safety via the App before your first ride. For your safety, your new Electric scooter is not activated and will beep occasionally after it is Power ON.

Until activated. The Electric scooter maintains very low riding speed, and cannot be ridden with full function. Install the App on your mobile device(with Bluetooth 4.0 or above).

Connect to the Electric scooter with Bluetooth, and follow the App instructions to activate your Electric Scooter and enjoy the full performance.

APP: Scan the QR code to download the App.

1 Install the App and register/log in.

2 Power on the Electric scooter. A blinking Bluetooth icon indicates the Electric scooter is waiting for a connection.

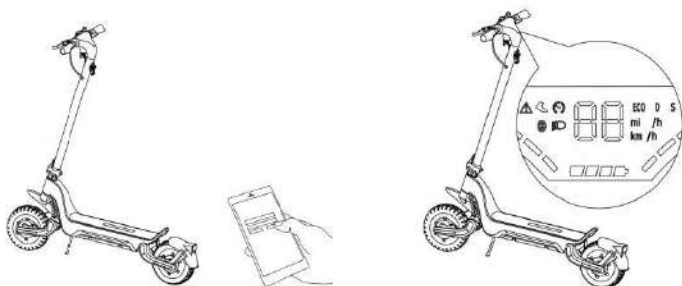

3 Click "Vehicle" - "Scan for Vehicle" to connect to Your Electric scooter.

When the connection is successful, the

Bluetooth icon will stop blinking and remain illuminated.

4 Follow the App instructions to activate the Electric scooter and learn how to ride safely. You can now start to use your Electric scooter. Check the status with App, and interact with other users. Have fun!

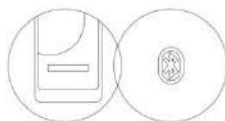

6 Charging

Charging step tips

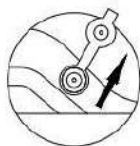
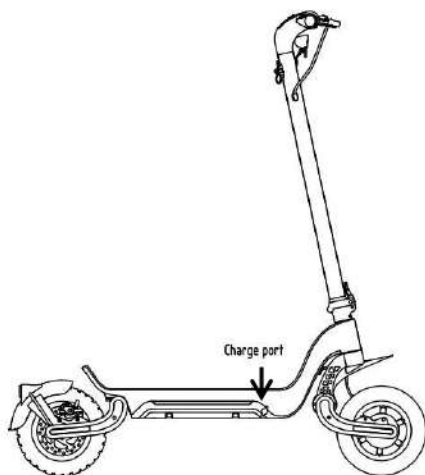

Open the charging
port cover

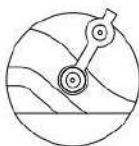

Plug in the charger
to charge

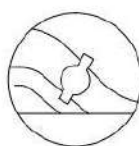

Cover the waterproof
cover

WARNING!

Do not charge if the charge port or power cord is wet.

Do not charge or use your battery if it is damaged or see a trace of water.

Close the charge port cover when not charging.

7 Learning to Ride



Wear an approved helmet and other protective gear to minimize any possible injury.

1. Power on the Electric scooter and check the power level indicator. Charge the Electric scooter if a low battery.



2. Stand on the footrest with one foot and push off with another foot to start gliding, to reach an initial speed of 3km/h.



3. Put your other foot on the footrest to keep both feet stable, and press the throttle. Starts sliding. On the right hand speed up when you are balanced.

13 Note, for your safety, the motor will not engage until the Electric scooter reaches 1.86mph (3km/h).

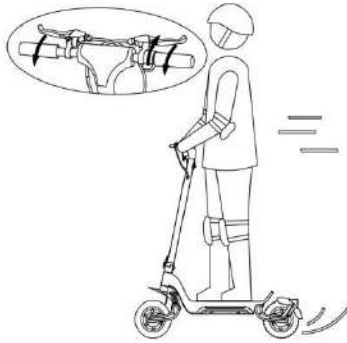

4. Take note of the brake levers, and operate the rear brake lever first rather than the front brake lever.

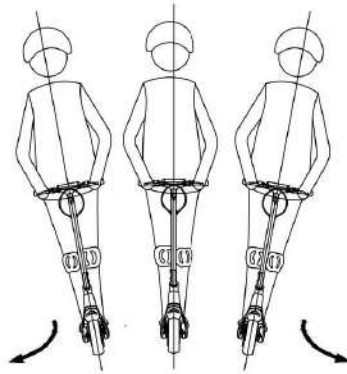

5. When turning around, the body should be turned in the same direction, and slowly operate the handlebar.



6. Put down the kickstand when parking.

▲ WARNING

When hard braking, you risk serious injury due to loss of traction and falls.

Maintain a moderate speed and look out for potential hazards.

Folding and Carrying

Folding:

Make sure the vehicle is off and fold it as the below picture shows. Lift ① up, pull ② out and press ③ will finish the folding.

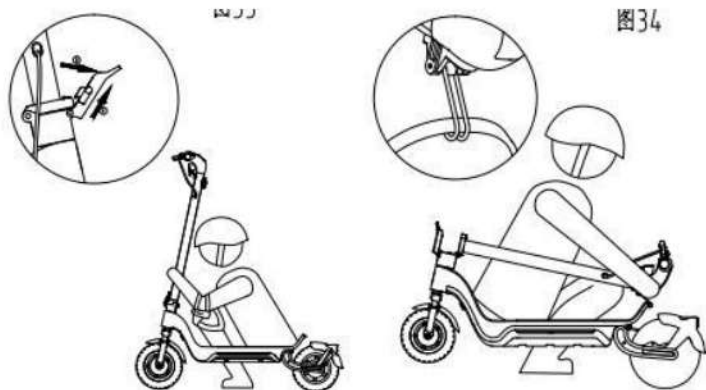

Carrying:

One hand or two hands carrying after folding.

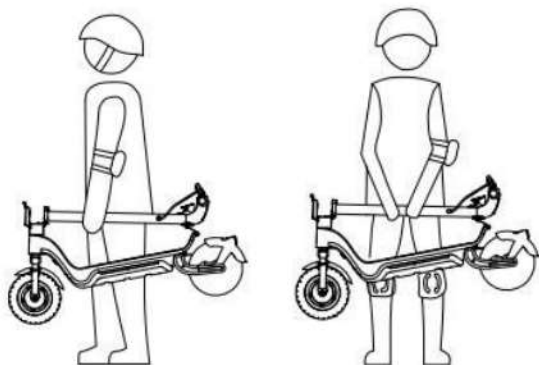

8 Warnings

WARNING

Failure to follow these instructions could lead to serious Injury.



DO NOT ride the speed bumps, thresholds, or Kick scooters in the rain.

DO NOT GET Wet.

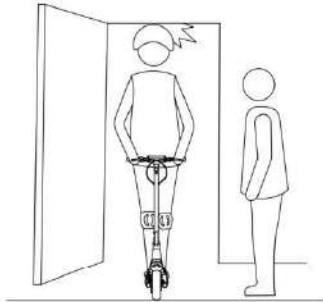

Watch your head when passing through doorways.



DO NOT ride over Or other bumps at HIGH SPEED.



Do not keep your feet on the rear fender.



DO NOT press the throttle when walking with the Electric scooter.



Avoid contacting obstacles with the tire/wheel.

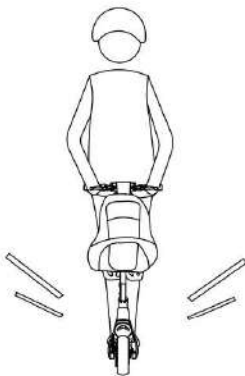

DO NOT carry heavy objects on the scooter with Handlebar.

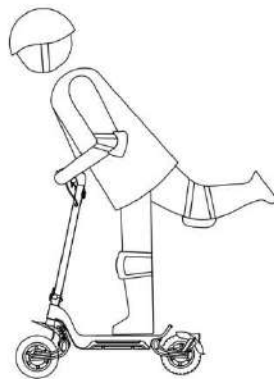

DO NOT ride the Electric scooter on only one foot.



DO NOT ride on public roads, motorways, or highways while driving.

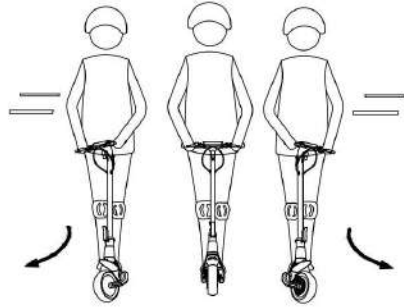

DO NOT rotate the handle violently while driving at high speed.



DO NOT ride through puddles or other bodies of water.



The Electric scooter is for one rider Only. Do not carry any passengers. Do not carry a child. Do not ride when pregnant.

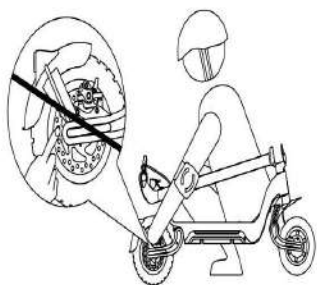

DO NOT touch the hub motor after riding because it can get hot.



Do not leave the handlebars with both hands.

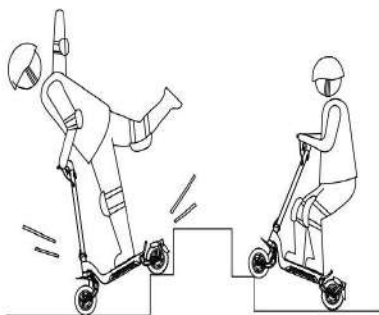

DO NOT ride up and down stairs or jump over obstacles.



Do not use a mobile phone or wear when operating the Electric scooter.

WARNING

Always keep both hands on the handlebar or you risk serious injury due to loss of balance and falls.



WEEE Disposal and Recycles Information Correct Disposal of this product. This marking indicates that this product should not be disposed of with other household wastes throughout the EU.

To prevent possible harm to the environment or human health from uncontrolled waste disposal. Recycling is responsible to promote the sustainable reuse of materials and resources. To return your used device. please use the return and collection systems or contact the retailer where the product was purchased. They can take this product for environmentally safe recycling.

Battery recycling information for the European Union



Batteries or packaging for batteries is labeled in accordance with European Directive 2006/66/EC and amendment 2013/56/EU concerning batteries and accumulators and waste batteries and accumulators. The Directive determines the framework for the return and recycling of used batteries and accumulators as applicable throughout the European Union. This label is applied to various batteries to indicate that the battery is not to be thrown away. but rather reclaimed upon the end of life per this Directive.

In accordance with the European Directive 2006/66/EC and amendment 2013/56/EU, batteries and accumulators are labeled to indicate that they are to be collected separately and recycled at end of life. The label on the battery may also include a chemical symbol for the metal concerned in the battery(Pb for lead, Hg for mercury, and Cd for cadmium)

Users of batteries and accumulators must not dispose of batteries and accumulators as unsorted municipal waste. but use the collection framework available to customers for the return, recycling, and treatment of batteries and accumulators. Customer participation is important to minimize any potential effects of batteries and accumulators on the environment and human health due to the potential presence of hazardous substances

Before placing electrical and electronic equipment(EEE)in the waste collection stream or waste collection facilities. the end user of equipment containing batteries

and/or accumulators must remove those batteries and accumulators for separate collection.

Maintenance

When meets problems, please do maintenance following our below instructions:

● **Clean recommendations**

1. When a surface is dirty, please use a wet cloth to make it clean. If meets oil or others, please use toothpaste to clean, and then clean with a dry cloth.
2. When meeting scratch in the surface, please use sand paper to softly polish.
3. Can't use any alcohol, gasoline, and any other corrosive chemical solvents to clean.

● **Storage**

1. When not in use, try to store the vehicle indoors in a dry and cool place, and try to avoid long-term storage outdoors. The sun exposure/hot and cold outdoor environment will accelerate the appearance and tire aging and reduce the service life of the vehicle.
 2. Do not use others' battery packs, otherwise, there may be safety risks.
 3. Do not touch the battery contact, and do not disassemble the battery to avoid short circuits and battery damage, or human injury.
 4. Only use the original charger to charge, otherwise, there is a risk of damage or fire.
 5. Please comply with local regulations when disposing of the battery.
- Please store the battery fully charged after each use, which is beneficial to prolong the battery life.

Please remember to contact with our shop for below items when you can not do by yourself.

1. Replace wheels
2. Replace brake plate
3. Replace brake pads
4. Replace cables
5. Replace wear parts
6. Replace electronic components

7. Replace tightening torques

- Our shop address: Gelfertstraße 45 Haus 1 ,14195
contact phone: 017657844824

Parameters

S9 PLUS

S9 PLUS DUAL

Specificati	Item	Parameters	Parameters
Size	LxWxH①	1170*530*1260mm	1170*530*1260mm
Net weight	Net weight (kg)	22	22
Riding Requirements	Recommended age (Y)	16-50	16-50
	Recommended height(CM)	120-200	120-200
	Max. pay load (kg)	120	120
Main Parameters	Max speed(Km/h)	25	25
	Max distance(Km)	40-60	50-70
	Max climbing degree	25	30
	Terrain	Flat terrain, lower than 1cm step	Flat terrain, lower than 1cm step
	Working temperature(°C)	-10-40	-10-40
	Storage temperature(°C)	-20-45	-20-45
	IP	IPX5	IPX5
Battery	Rated voltage (VDC)	48V	48V
	Max voltage (VDC)	54V	54V
	Rated capacity (Wh)	624/720	864
	BMS	Short circuit/undervoltage automatic sleep/over current/double over charge and double over discharge protection	Short circuit/undervoltage automatic sleep/over current/double over charge and double over discharge protection
Motor	Rated power (W)	350	500
	Max power (W)	500	700
Charger	Rated power (W)	108	108
	Input voltage (VAC)	100-240~	100-240~
	Output voltage (VDC)	54	54
	Rated ampere (A)	2	2
	Certificate	RoHS,CE	RoHS,CE
	Charging time (h)	6-8	6-10

① Height: Distance from ground to the highest point of vehicle.

② Max distance : Based on below requirements: full battery capacity, 75Kg, 25°C, flat road, no wind and keep the same speed.

DECLARATION OF CONFORMITY

Business name of the factory:

Ningbo Sunhon International Co., Ltd.

full address of the manufacturer:

Room 2-2, Building 6, Chenjia Village, Zhangqi Town, Cixi, Ningbo, Zhejiang, China

Business name of authorized representative (if appropriate):

Mo&Wen Electronics International GmbH

full address of authorized representative:

Gelfertstraße 45 Haus 1 ,14195

Name and address of the person (established in the Community)

compiled the technical file: Sandy Tong

We declaring that the machinery:

product name: Electric scooter

commercial name: Electric scooter

function: Commute

model: S9 PLUS/S9 PLUS DUAL

type: Class II

Serial Number: e.g SH2232B15001

Fulfills all the relevant provisions of Directives :

EMC Directive (2014/30/EU),

Machinery Directive (2006/42/EC), Noise emission...by equipment for use outdoors (2000/14/EC+Amd. & Corr.),

WEEE Directive (2012/19/EU),

RoHS Directive (2011/65/EU),

Batteries, Accumulators and Waste Batteries (2006/66/EC)

Low voltage directive (2014/35/EU) for charger only

Tested in accordance with below standards:

EN17128:2020

ISO 12100:2010

EN 60335-2-29

EN 55014-1

EN 55014-2

EN 61000-3-2

EN 61000-3-3

Place and date of the declaration: Cixi, China, 2022/10/1

Identity and signature of the person empowered to draw up the declaration: Fanny