

USER'S MANUAL

Model G63



Dual Motor



Single Motor

Thank you for purchasing an electric scooter!

This electric scooter is an environmentally friendly high-tech product, a new type of transportation tool with excellent shock absorption, portability, flexibility, good riding comfort, high safety and reliability.

Please read the user manual carefully to understand its features, technical parameters, safety precautions, after-sales service and proper use and maintenance.

1. Do not use the scooter until you understand the user manual and its performance.
2. Do not lend your electric scooter to anyone who cannot operate it, pregnant women are prohibited.
3. Before driving the electric scooter, please check carefully whether the braking system works well.
4. Keep the charger well ventilated and dissipated when charging, and do not charge the scooter at high temperatures.
5. When replacing the motor or tire, make sure the wheel screws are tightened. Any loose wheel screw can lead to a major accident.
6. Do not arbitrarily disassemble or modify the circuits or components of the scooter.
7. Please wear appropriate protective clothing such as helmet, knee pads, elbow pads, wrist guards. We recommend that you wear the best outdoor sports equipment.
8. If there is any abnormality in the scooter, please turn off the power of the scooter and stop driving it.
9. The images contained in this user manual may differ from the scooter you received. The images are for reference only, and the actual product is the standard.
10. If you do not use the electric scooter for a long time, please turn off the battery power. If you do not use the electric scooter for a long time, you need to charge it regularly to avoid battery self-consumption and failure.
11. The performance and configuration of the scooter may be improved from time to time and cannot be changed without prior notice.

safety instructions

For adult use only!

Please obey local traffic laws!

Don't go up too fast! If you drive too fast or too fast, you risk falling.

Do not drive when the electric scooter battery is low, you may fall over when the battery is exhausted.

Please enjoy your ride

USER'S MANUAL

Model G63



Dual Motor



Single Motor

 **ATTENTION**

- Read and understand this entire manual before riding.
- Have this manual at reach

CONTENTS

- 1. Safety instructions**
 - 2. Package contents**
 - 3. Components diagram**
 - 4. Assembly and set up**
 - 5. App control**
 - 6. Folding and unfolding**
 - 7. Technical parameters**
 - 8. Care storage and battery/controller**
 - 9. Warranty**
-

1. SAFETY INSTRUCTIONS

Please check whether the scooter drives normally before each drive. Do not use if any part is loose or damaged, especially the braking system.

1. Description

Please read this manual carefully before using the scooter.

Do not use electric scooters in dangerous situations. Do not use where flammable gases, vapors, liquids, dust or fibers may present a fire or explosion hazard.

Whenever you drive an electric scooter, you need to wear a suitable helmet, knee pads and elbow pads, and use a qualified skateboard helmet that provides protection for the back of your head.

Consider using additional protective equipment such as gloves, eye protection, wrist guards, and knee pads. And provide adequate protection and comfort, mainly depends on your driving environment and your driving experience.

Found new drivers, please tell them the basic scooter operation, newbies are advised to drive the scooter with caution. The safety of the new driver is your responsibility. Do not let new drivers operate the scooter outside of your direct supervision unless they have read the owner's manual.

Avoid driving on slippery, waterlogged, rough roads. If you can't avoid it, stop, get out of the car and push the cart forward.

Be especially careful when riding in tight spaces or near obstacles.

Use with care on slopes and when ascending, descending or over rough terrain.

Do not attempt to drive on slippery, waterlogged, rough roads.

When turning! Please drive slowly and carefully. Rapid turns can cause the scooter to lose control or slip.

When you encounter slopes, uneven terrain or other terrain, do not risk riding it if you are inexperienced or make the crisis safe for you.

Don't wear loose clothing that could get caught in the tires, and don't steer aggressively.

Electric scooters are designed to be driven by a single driver and do not carry any passengers.

Do not hold your child in your arms when driving an electric scooter, and pregnant women are prohibited from driving an electric scooter.

Do not exceed the maximum load limit (including driver and all cargo) specified in the owner's manual. Otherwise, you may be at great risk.

Never ride on stairs or turnstiles. Riding on stairs, escalators, turnstiles is extremely dangerous.

Don't jump down during use, just come down after you stop.

Do not drive the scooter in low visibility conditions.

To drive safely, you must be able to see clearly what is in front of you, and you must clearly see others.

Be vigilant, as with any other transport device, you must be mentally alert to drive your scooter safely. Do not attempt to drive an electric scooter if you are sick or cannot follow the instructions completely. Do not drive under the influence of alcohol or drugs and avoid distractions. Do not use your cell phone, listen to headphones, or engage in any other activity that may distract you or interfere with your ability, please observe your surroundings, be especially careful when

approaching intersections, and be ready to brake at all times.

At intersections, corners, doorways, and other complex areas, you need to slow down or stop. Avoid motor vehicles, cyclists or pedestrians.

When riding, keep your hands on the handlebars and keep your feet firmly on the scooter. A relaxed pose with knees and elbows slightly bent. Do not carry any objects.

Never restart and drive your scooter when the electric scooter has indicated a low battery alarm or performed a low battery safety shutdown. The scooter may not have enough power to drive, especially if you need a lot of power at the same time. If you restart and keep driving, your risk goes up.

Also, you may damage the battery, reducing battery life and capacity.

Be very careful when driving on the highway, or crossing the road. Stay as far away from people as possible and allow plenty of time to cross the road. Make sure that driving on the road is legally permitted in your area.

The total weight of any handle payload plus any other accessories should not exceed 4.5kg hanging from the handle. Exceeding this limit will interfere with the balance ability of the electric scooter and may cause the scooter to accelerate on its own or cause injury and other losses.

Do not drive the scooter if you encounter any balance obstacles.

Generally speaking, it is not recommended for minors to drive scooters.



2. Safety hazard, be careful to avoid

1 Please avoid riding in the rain

2 When encountering unconventional roads such as speed bumps/elevator thresholds/potholes, please do not pass at high speed. Please maintain a medium-low speed (5-10km/h) on rough roads. Bending your knees slightly can help you better adapt to the above complex roads

3 Avoid hitting your head against high obstacles such as door frames and elevators

4 When walking with the electric scooter, do not press the accelerator switch

5 Please avoid obstacles and ride

6 Do not hang heavy objects such as backpacks on the handlebars

7 Do not put one foot on the pedal or the ground while riding

8 It is forbidden to ride electric scooters up and down steps or over obstacles



3. Dangerous action, do not attempt

1 It is forbidden to ride electric scooters into the residential area where the motorway and people and vehicles are mixed

2 It is forbidden to turn the handlebars sharply during high-speed driving

3 It is forbidden to drive in standing water exceeding 2cm

4 It is forbidden for more than one person to drive an electric scooter at the same time or drive with children

5 Do not step on the rear end of the fender

6 Do not touch the brake disc

7 Do not hold the handlebars while driving

8 It is forbidden to ride electric scooters up, down steps or jumping obstacles

2.PACKAGE CONTENTS

ATTENTION

Check the package contents, please come to your distributor or retailer if anything is missing.

It includes the following parts inside the box:



Accessories

User Manual	Screws	Spare Tool	Charging Adapter
-------------	--------	------------	------------------

Note: The product you receive may not exactly match the contents of the manual. Due to different product configurations, the actual product received shall prevail. For details, please contact your distributor's customer service to handle it for you.

3.COMPONENS DIAGRAM AND SIZE

1.Componenes diagram

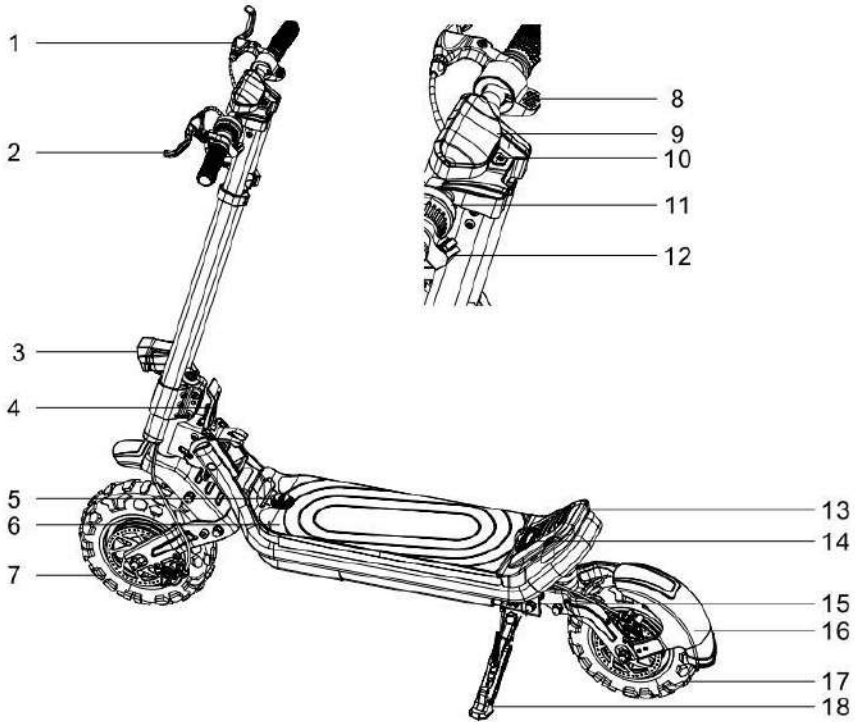

1. Front disc brake	10. Power button
2. Rear disc brake	11. Bell
3. Front light	12. Dual/single motor switch
4. Folding mechanism	13. Taillight
5. Coded lock	14. Seat mounting hole
6. Battery compartment	15. Charging port (Right & Left)
7. Front wheel motor	16. Mudguard
8. Throttle	17. Rear wheel motor
9. Dashboard	18. Kickstand

2.Size

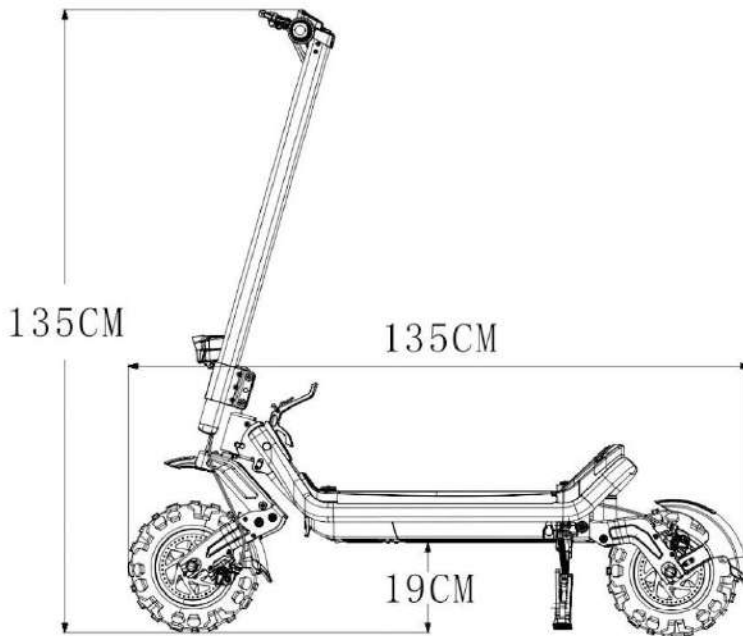

Please understand that there is a tolerance in the size

Thank you for purchasing our electric scooter.

This manual contains information of the update product information available at the time of printing. We reserve the rights to make amendments without advance notice and without incurring any sequent obligation.

4.ASSEMBLY AND SET UP

1. Assembly

1.Put down the scooter and make the scooter stable



2.Loosen the 4 screws on the handlebar steering valve. Put the handlebar on the steering stem, pay attention to the correct position, and tighten the screw with the tool



3.Install the headlight, align the screw position of the seat fixing piece and lock the screw

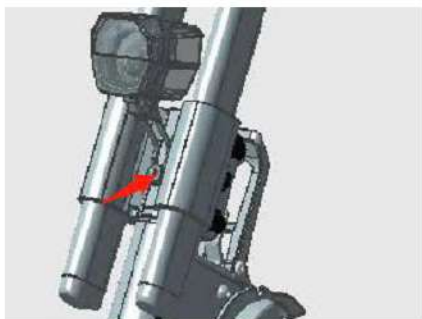

4.To assemble the rear fender, install the rear fork and the fixing holes on both sides and tighten the screws



5.After assembly, turn on the battery switch and power button below dashboard to check if it's working properly



2. Digital Display

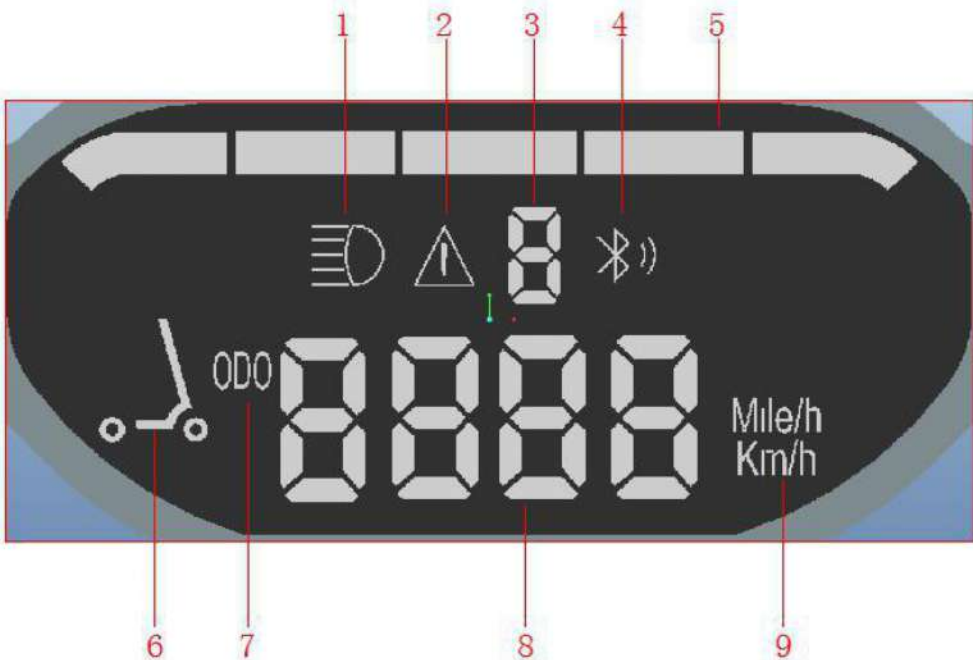

1. Front light	6. Dual / single motor display
2. Fault display	7. Mileage
3. Gear	8. Speed
4. Bluetooth	9. Mile/KM display
5. Battery level	

The above functions are not supported by some models, please refer to the actual product received

- Battery Inventory (point 5 in above diagram):

There are 5 Leds showing the battery inventory levels

- Change speed mode:

When the scooter is on, quickly press power button and the display reflect the speed mode gear 1/2/3.

- Turn ON/OFF the scooter:

To Turn ON:when the scooter is off,press power button shortly

To Turn OFF:when the scooter is on,press power button for 3 seconds

- Turn ON/OFF the lights:

To turn on/off the lights(front and rear),press power button twice in a row,when the lights are on,display reflect it(1 in the diagram)

- Start Mode

Press power button 4 times in a row to switch from zero start mode to non-zero start (kick-to-start)

(The default setting of electric scooters is non-zero start. Zero start means directly pressing the accelerator to start)

- Switch dual motor to single motor(Note: single motor models do not need to operate)

The factory default is to start with dual motors. After use, it will memorize the drive mode used last time, and it will not memorize under abnormal conditions. (For example: switch to the rear motor after booting up, and then remove the battery directly or turn off the battery power without shutting down)

Click the motor switch to cycle in sequence (dual motor -- rear motor -- front motor -- dual motor)

When the motor is switched to single motor, there will be 1 beep of "di..." and 2 beeps for dual motor.



- Switch KM to Mile:

Press power button three times in a row to switch kilometers to miles

- Total mileage display:

Press twice motor switch to display total mileage



There may be a mileage value display after leaving the factory, this value is the test value.

Manufacturers normally use confidential permissions to clear test values after testing.

- Adjusting brake disc

When the brake is too tight or too loose, use a 4mm Allen wrench to loosen the screw on the caliper. Slightly adjust the brake line to a suitable place, then tighten the screw.

- Adjusting handle bar

Prolonged use of the scooter may cause screws to loosen, making the handlebar shaft unstable. When it occurs, just tighten two screws located on the folding mechanism.

3. Charge the scooter

Removal battery set and dual charging port design with 2 chargers available at the same time.

1. Lift the rubber flap from the bottom of the electric scooter
2. Plug the charging adapter into the charging port

Charging:

To maintain optimum performance of the scooter battery, charge the battery for at least 5 hours per month when not in use.

Charge the battery only when it is within the specified charging temperature range.

Charging time varies depending on the following conditions:

- a. The battery has stored power, and if the stored power is lower, the charging time will be longer.
- b. Battery temperatures that are too hot or too cold may not charge or may take much longer to charge.

Recommended charging temperature range:

- a. Do not charge the battery if the storage temperature is below 32° F/0° C.

Charging ambient temperature (above 50° F/10° C). Doing so will ensure optional battery life and performance.

- b. Do not plug in the power cord if the charging port, power cord, or AC outlet is wet.

Charge the battery:

- 1) Put your scooter in a clean and dry place within the recommended charging temperature range.
- 2) Open the charging cover on the charging port, behind both sides of your scooter.
- 3) Verify that the charging port, power cord and AC outlet are clean, dry and free of debris.
- 4) Plug the other end of the power cord into the charging port (the green indicator will turn green).
- 5) Plug one end of the power cord (provided with your scooter) into a grounded AC outlet(100V-240V: 50Hz-60Hz). The power cord should be properly grounded (indicator will turn red).

ATTENTION

When charging is completed, put back the rubber flap. The red indicator will turn green again.

Note: Please do not let your scooter charge for more than 12 hours.

Please note the following before riding:

When you are ready to use the scooter, remove the power cord and close the charging port.

Disconnect the power cord from the AC outlet.

Disconnect the power cord from the charging port on the electric scooter.

Disconnect the charger.

Close the charging port cover.

Always keep the charging port cover closed unless you are charging the scooter. Closing the charging port cover can prevent water, dirt, dust and other pollutants from entering the charging port and causing damage to the scooter.

Instruction

- 1) Charge the lithium battery in the temperature range of 0°C to +45°C.
- 2) Keep charging for 6-8 hours.
- 3) Only use the dedicated charger to charge your scooter.
- 4) Local charger AC input voltage (100~240v).
- 5) Turn off the power before charging.
- 6) Make sure the charger is connected to the scooter first, then plugged in. Otherwise the charger hole may be damaged.
- 7) Do not place the charger and board in a damp place, not near water.
- 8) Note: Keep away from other items by not less than 20 cm, not on the sofa, bed or carpet. Do not cover the charger and keep it ventilated.
- 9) Do not place any weight or heavy objects on the scooter and charger.
- 10) Unauthorized modification of the scooter is prohibited, otherwise the warranty will be voided and the risk of injury and electricity will be created.
- 11) The light is red when charging. When the battery is full and the light turns green, unplug it. Do not recharge the battery within 2 hours.
- 12) Please be under the supervision of people when charging.

Charging failure

If a malfunction is detected during charging, stop charging.

Check the following conditions:

If the charging indicator is off, please check whether there is AC power and make sure that the power cord is fully connected to the charging port.

If AC power is present and the charging indicator is off, it means there is a problem with the charger. Contact the distributor of the scooter.

Please do not use different types of chargers when charging. Only use a dedicated charger. Do not use one charger to charge several different electric scooters. The charger may be damaged during work.

Do not disassemble the charger, please contact the scooter distributor when you need to repair or replace it.

Surface charge (partial charge)

Whenever you have not fully charged the battery of the scooter, surface charging or partial charging may affect the accuracy of the dashboard display, making it display a higher battery level.

After turning on the power, observe the dashboard, and then ride for at least three to four minutes, and check the power display on the dashboard again. During this period, the battery display is less, indicating that the battery has only received surface charge. If necessary, need to push it back to charge.

4. Battery coded lock reset

Battery box password lock Factory password: 000

Note: When the battery box is installed in the frame, the combination lock must be unlocked to avoid crushing the internal iron plate



Reset Instructions:

- a. The password must be set in the unlocked state (the factory default setting is 0-0-0)
- b. The password reset position is in the small hole under the outer bevel, rotate the head until you can see the button inside
- c. Push the button with a small cylindrical object and hold it down
- d. Turn the password wheel to the position where the number you want to set is in the middle
- e. Release the button to complete the password setting
- f. Lock: Rotate to the locked state, and after locking one or all of the code wheels, it will be locked.
- g. When unlocking, dial the set password.

Note:

After changing the new password, please try to see if the password setting is successful and record your new password to avoid being unable to open if you forget your password if you do not use it for a long time.

5. How temperature affects performance

Batteries are usually above air temperature

(1) Riding in high or low temperature

It is recommended to ride within the recommended temperature range. As with all batteries, you may not be able to travel the same distance when the battery is cold.

(2) Charging at high or low temperature

Your battery should be charged within the recommended charging temperature range. It is most efficient to charge the battery within the temperature range that the battery is suitable for. If your batteries are too hot or too cold, they may take longer to charge, or they may not charge.

6. Replacement battery

Your scooter is powered by a rechargeable lithium battery. Batteries have a limited lifespan.

Near the end of their useful life, they will require more frequent charging and the range of your scooter ride will decrease. To order replacement batteries, please contact your distributor.

7. Battery removing and mounting instruction

1.Unlock coded lock of battery, pull up the red buckle, release triangular thread hook



2.Hold the handle of battery set and lift it up to remove the battery.



3.When the battery is installed in the frame, first adjust the combination lock to "unlocked state". This step is very important to avoid crushing the internal iron plate.



4.After the battery is installed in the frame, fix the triangular hook inside the inverted buckle, and pull down the red buckle to fix the battery.

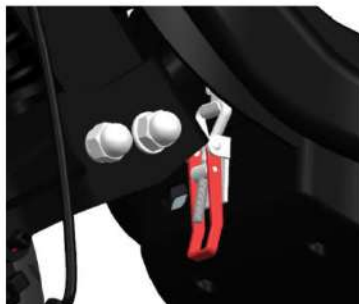

5. Rotate the combination lock to the locked state, and scramble the digital wheel to complete the lock



5.APP CONTROL

1. App Download

The scooter(app version) can be controlled by Tuya after you install it.



Scan the QR code and download the app

Download Tuya App from your application store or by scanning above QR code,then follow the instructions to install.

A. Account registration → Login account → Add device

B.Add device steps:



C.Enter the setting interface

2. App Function

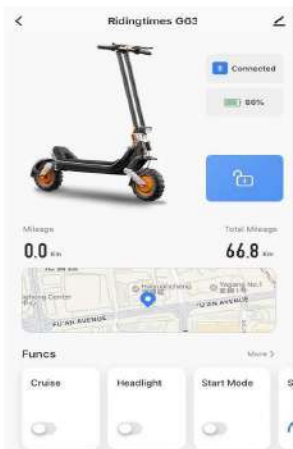

Connected to your mobile phone over bluetooth to monitor the scooter status

- Motor lock/unlock
- Speed mode switch
- Light on/off
- Battery levels
- Mileage
- Fault analysis
- Positioning
- Customized data display on panel

3. Application Function Settings

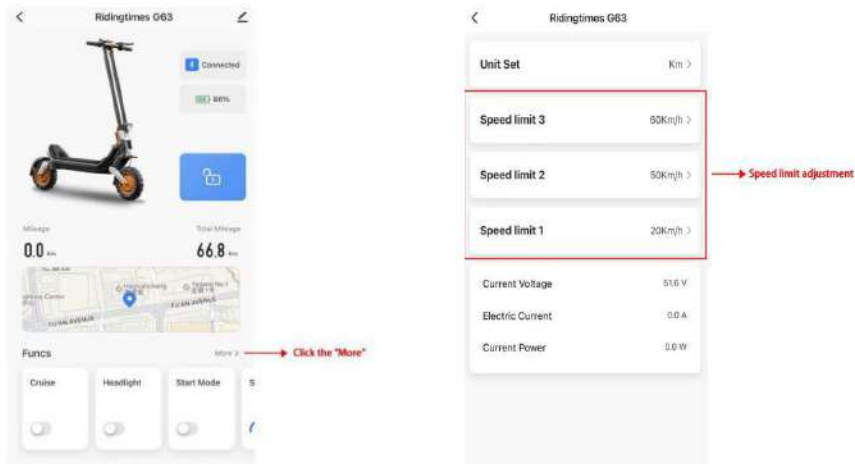

- A. When connecting to the APP, please turn on the Bluetooth and positioning switch in the mobile phone first.
- B. The speed will be set in a safe range before delivery (considering the safety of consumers), if need to release the speed, use the Tuya APP to set the following data:
Dual-drive: First gear 20km/h, Second gear 45km/h, Third gear 60km/h
Single-drive: First gear 15km/h, Second gear 30km/h, Third gear 50km/h
The actual product shall prevail.

4. Troubleshooting for the failure of app connecting to scooter

- A. When exiting the APP, please follow the steps below:

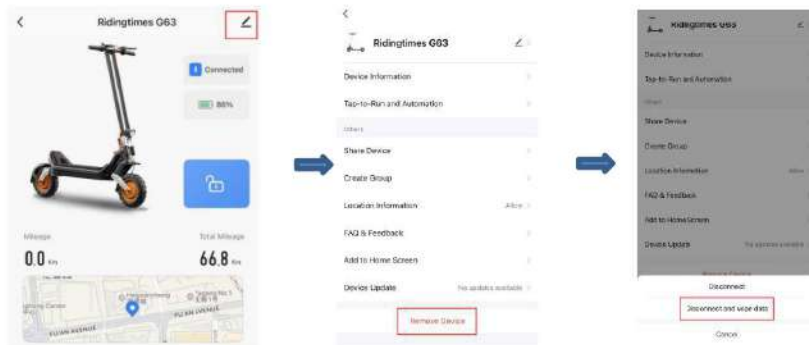

- B. If the scooter has been connected to another mobile phone, please disconnect and reconnect with the current phone.
- C. If it still doesn't work, need to clear the connected mobile phone data, please turn off the scooter: In the state of ensuring the shutdown, press the brake lever on either side and ON button at same time for 5 seconds, when you hear a 'di' sound, setting is successful.

Note: After receiving the scooter, please follow the above steps to enter the APP to operate.

6. FOLDING AND UNFOLDING

Scooter body folding/unfolding

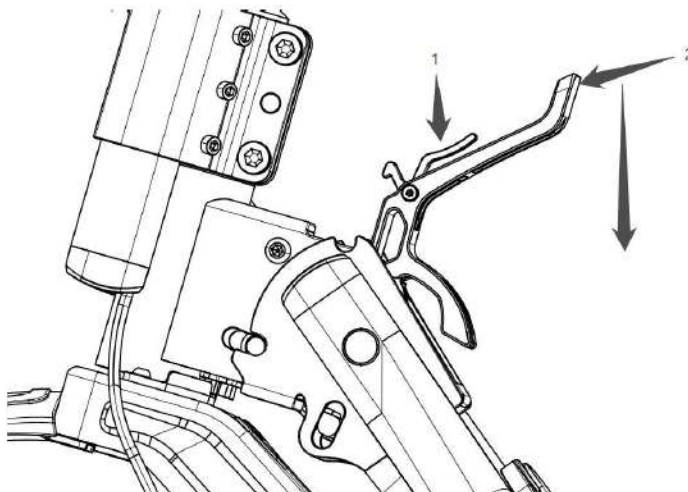

-Fast folding for 3 seconds: Press 1 anti-unhooking in the above figure, hold the 2 wrench , press it down and fold the steering lever down to complete the folding.

-Fast folding for 3 seconds: fold the steering rod upwards, hold the wrench 2, pull it upwards and buckle the anti-tripping. (The new scooter may have the phenomenon that the tight fitting is not in place, please use it with confidence.)

Note: After the folding position passes through the running-in period for a period of time, folding will produce a virture position. The adjustment method can be solved by properly locking the "nut" under the center axis.



7. TECHNICAL PARAMETERS

	48V Dual Motor		48V Single Motor
Battery	48v 20AH		48v 15AH
Battery weight	About 8.55KG		About 7.3KG
Motor	1200W*2		1200W*1
Intelligent System	 Tuya APP None-key start + Motor Anti-theft Locking +man-machine Interaction		
Optional	Removable battery set and seat		
Brake	Front & Rear Mechanical brake +EABS		
Tyre	11" Pneumatic Off-road Tyre	11" Pneumatic Street Tyre	11" Pneumatic Street Tyre
Absorber	Front & Rear shock Absorber		
Testing Environment	26°C		
Climbing Angels	20<		15<
Charging Time	Charger x1 , 10-12Hrs/ Charger x 2, 5-6Hrs		Charger x1 , 8-9Hrs/ Charger x 2, 4-5Hrs
Display	Digital display		
Material	A3 Carbon Steel + 6061 Aluminum Alloy + Cover Plastic PA66		
Net Weight	About 38 Kgs		About 32.5 Kgs
Gross Weight	About 45 Kgs		About 40kgs
Product Size	135x50x135CM		
Folded Size	150x50x50CM		
Carton Size	148x25x51CM		
Max Load	130KG		
Max Speed (KM/H)			
	11" Pneumatic Off-road Tyre	11" Pneumatic Street Tyre	Single Motor
	55km/h	60 km/h	50 km/h
Max Range			
	11" Pneumatic Off-road Tyre	11" Pneumatic Street Tyre	Single Motor
	About 50KM	About 60KM	About 50KM

8. CARE STORAGE AND BATTERY/CONTROLLER

1. Clean and store electric scooter

The scooter is designed to be virtually maintenance free, with all parts installed and working properly, the battery charged, and the tires properly inflated for riding. Do not turn on the scooter, motor or motor. These parts are not user serviceable parts.

Make sure the scooter is turned off and unplug the scooter's power supply or charger before following the procedure below.

a. Check the electric scooter

Be careful with your fingers! Do not grab tires, fenders or wheels.

Because your hands or fingers may be injured, resulting in personal injury.

b. Maintenance of tires

Tire pressure should be appropriate. Higher pressure reduces suspension performance and traction, and increase the risk of loss of control, collisions and falls. Lower pressures reduce the range and increase the risk of tire/wheel assembly damage. To ensure safe and efficient operation of your scooter, be sure to inspect tires and wheels regularly especially if you have recently had tire/wheel assembly services.

c. Check the tire/wheel assembly

Check tires and wheels:

- 1) Make sure the scooter is unplugged and powered off.
- 2) Wheel assembly Check the wheel rotation and try to move the vehicle. The tire/wheel assembly should not move laterally. If you detect wheel wobble, check the wheel nuts and tighten if necessary.

d. Tire pressure

The tires on the scooter provide suspension and traction, both of which are affected by the tire pressure. When the single tire pressure is too low, please pressurize the tire in time.

Please note the following:

- 1) Make sure the scooter is unplugged and powered off.
- 2) Regularly check the tire pressure, improper tire inflation can lead to accidents.
- 3) If the tire pressure is not at the level specified in "Scooter Specifications" on any tire, please adjust the tire pressure to the specified pressure.
- 4) Check that both tires are equally inflated and free of debris or contamination.

e. Clean your scooter

Do not use any specialized cleaners to clean brushes or other corrosives. The use of such products may reduce friction and increase the risk of slipping.

To clean your scooter:

- 1) Make sure the scooter is unplugged and powered off.
- 2) Always close the charging port cover after charging and before cleaning.
- 3) Gently clean your scooter with soap, water and a soft cloth.
- 4) Avoid flooding your scooter

2. Maintenance of Electric Scooter Battery

Do not expose the battery to temperatures above 50°C or low temperatures below -20°C (For example, do not place the battery pack in the sun), otherwise it may cause the battery to malfunction, overheat, or even catch fire. For other battery maintenance precautions, see the battery pack nameplate located under the body.

Avoid completely draining and recharging the battery. Use it as much as possible. This will greatly extend battery life. Additionally, the battery can achieve higher cruising range and performance when used at room temperature, which will degrade if used in sub-zero environments. Typically, at -20 C, the cruising range may be half or less than normal temperature. The battery's cruising range will resume as the temperature rises.

A full charge has a standby time of about 60~90 days, after which the stored power is exhausted; if it is not charged in time, the battery may be damaged. This damage is irreversible, and the damage caused by not charging for a long time is not covered by the free warranty. (Note: Non-professionals are prohibited from disassembling the battery, otherwise serious safety accidents may occur due to electric shock or short circuit)

3. Storage Recommendations

1) Store the battery and charge it at a temperature of -20~35°C, not in a low humidity, corrosive gas environment.

2) Long term storage:

In the case of long-term storage (more than 3 months), store lithium batteries in a temperature range of 10~20°C, low humidity, and no corrosive gas atmosphere.

2) Do not store other items on the lithium battery.

4. Battery safety

1) Do not use the battery if the battery case is damaged or the battery emits an abnormal smell, overheats or leaks any substance. Avoid touching the battery with anything that seeps out.

2) Keep children and pets away.

3) Unplug or disconnect power from the scooter before removing or connecting the battery or connecting the battery. Never work near the scooter when it is plugged in. Otherwise you may suffer serious bodily injury from electric shock.

4) The battery inside the battery contains toxic substances. Do not try to open the battery. Do not insert any object into the battery or use any device to pry the battery case. If there is you may suffer an electric shock, burn or cause a fire. Attempting to open the battery case will damage the battery and may release toxic and hazardous substances and render the battery unusable.

5) Review, read and follow all safety information on the battery warning labels.

6) Insufficient charging of the battery for a long time may result in permanent damage to the battery.

7) Only use dedicated chargers, never try to bypass or override their charging protection circuit.

8) Do not wash the scooter with an electric washing machine or high pressure water gun to avoid putting water into the charging port. Always close the charging port cover after charging.

Failure to follow these instructions before plugging in the power cord could expose you to electrical shock, burns, or fire.

9) Do not submerge batteries and scooters, if you suspect batteries and scooters have been submerged or experienced water intrusion, contact your distributor until you receive further instructions. Storage scooters should be upright and outdoors away from flammable items. Do not try to remove the battery. Do not plug the power cord into the scooter. Failure to follow these instructions could result in electric shock, injury, burns, or fire. As with all rechargeable batteries, do not charge near flammable materials.

5. Battery Specifications

Battery type	48v 20AH	48v 15AH
Battery weight	Approx. 8.55kg	Approx. 7.3kg
Charging time	Single charger 10-12H/dual charger 5-6H	Single charger 8-9H/dual charger 4-5H
Operating temperature	(-20°C to 40°C)	(-20°C to 40°C)

6. Controller function description

S/N	Item	Function
1	Current limit value	Single motor 25A/Dual motor 18A*2
2	speed limit	Single motor: 15km/h in first gear, 30km/h in second gear, 50km/h in third gear Dual motor: 15km/h in first gear, 30km/h in second gear, 60km/h in third gear
3	ESC over temperature protection	Level 1: When the ESC temperature reaches 85°C, the ESC power will slowly decrease to 25%; when the ESC cools down and the temperature is lower than 75°C, the ESC will restore power; Level 2: When the ESC temperature reaches 105°C, the ESC will slowly turn off the power; when the ESC cools down and the temperature is lower than 100°C, the ESC will restore power by 25%;
4	Over current Protection	When there is a MOS short circuit or a short circuit between the output lines of the ESC, the ESC hardware emergency protection will directly cut off the power; after the fault is eliminated, the accelerator and brake will be reset for 4S and the speed will be less than 1km/h. Automatic recovery;
5	Under voltage protection	The ESC is detected during operation, when the total battery voltage is lower than 31V, the ESC will have no power, and the maximum braking force will be halved; after the voltage recovers, the ESC will resume work;
6	Over voltage protection	When the ESC is powered on to detect overvoltage, when the total battery voltage is higher than 56V, the ESC will have no power and no brakes; after the voltage recovers, the ESC will resume work;
7	Stall protection	In the zero start mode, if the motor speed is close to the stop time for more than 3s, the ESC will slowly turn off the power. When the motor speed recovers, the ESC will restore the power

9. WARRANTY

Accessories	Quality Issues	Warranty Period
Motor	The motor does not work under normal use	One year
Controller	Controller failure under normal use	One year
Charger	Charger failure under normal use	One year
Lithium battery	Battery failure under normal use	Half year
Body structure	Deformation under normal use or breakage	One year

Dear Customer:

Thank you for purchasing our electric scooter! In order to serve you better, please read it carefully.

Conditions apply

This warranty covers damage that occurs during shipping, such as motor not working, battery not supplying power, etc.

The electric scooter is guaranteed to be free for 1 year from the date of purchase.

Note: Warranty will not be provided in the following cases

- 1) Cases approved by the customer prior to delivery are not covered by these warranty terms.
- 2) Consumable and fast-wearing parts are not covered under warranty: LED lights, tires and tubes, full brake system, brake cables, plastic parts, covers, etc.
- 3) All man-made damage, such as wading, improper access to power, use of improper accessories.

One of the following cases is not covered under warranty, but a reasonable repair fee must be paid.

- 1) beyond the warranty period.
- 2) Serial numbers or labels of major parts deleted or destroyed by consumers.
- 3) The details on the warranty card do not match the physical identification of the goods or have been changed.
- 4) Damaged and unreasonable maintenance due to not using the reference product specification requirements.
- 5) Damage is caused by unreasonable dismantling of Party A without commitment to warranty.

Trademarks and Legal Notes

The content and technical specifications in this user manual are valid for printing where permitted. But our company has the right to change and change the technical specification or design. We will not be under any obligation without prior notice. This user manual contains images, function descriptions, and usage instructions for printing. They are for reference only and it may differ from the scooter you purchased due to improvements in product features, design changes, etc. from time to time. Some of the features, performance and configurations mentioned in the user manual may not be available and the scooter you receive is subject to the real scooter.
